



Service Information

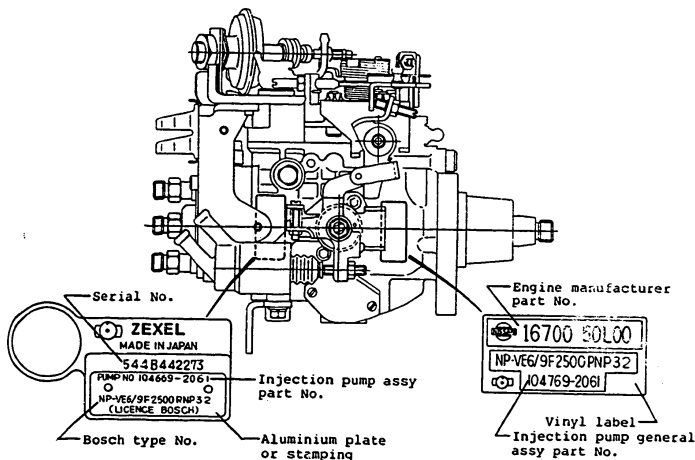
GENERAL

VE type Fuel Injection Pump Part Numbers

The part number system and name plate attaching position for the ZEXEL VE type fuel injection pump are as given below. They differ from the R. Bosch VE pump.

Always use a part number beginning with 1047 and refer to the microfiche for the calibration data and part list. (Do not use part numbers beginning with 1046).

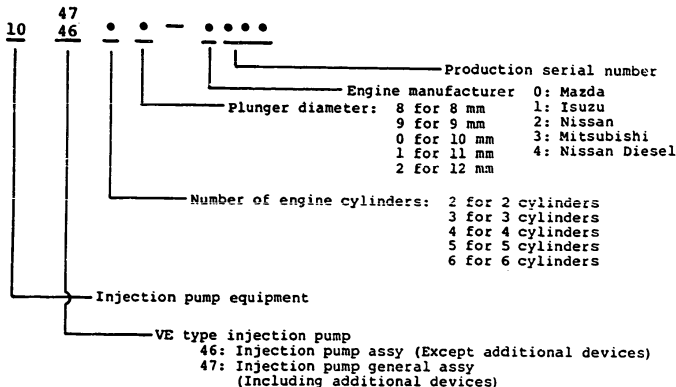
1. Location of part No.



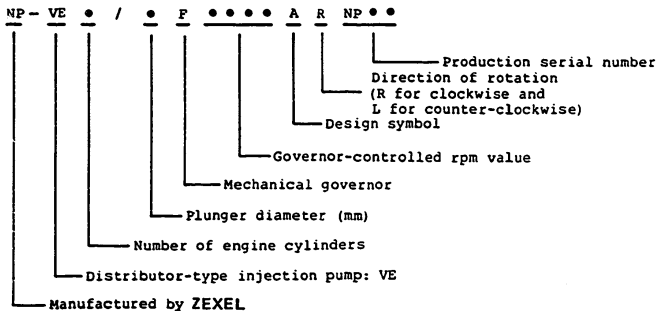
ZEXEL

2. Coded designation of VE type injection pump

(1) Code No.



(2) Bosch-type designation



3. Injection pump general ass'y part No. and injection pump ass'y part No.

An example is given on page 4.

- 1 The five digits used for the injection pump ass'y part No. increase to 12 digits for the injection pump general ass'y part No., to include different additional devices and specifications, etc.
- 2 Even if the 4th digit of the part number is changed from 6 to 7, it does not give the correct general ass'y number. Except for key numbers 2 and 11, the digits other than the 4th digit are also different.

For example

No.	INJECTION PUMP ASS'Y PART NO.	INJECTION PUMP GENERAL ASS'Y PART NO.	ENGINE		ADDITIONAL DEVICE (1)				REMARKS	
			MANUFACTURER	MODEL	PICK- UP	ACTU- ATOR	DASH- POT	CSD		OTHERS
1	104640-4681	104740-4701 (16700 18G 02)	NISSAN DIESEL	SD23	-	-	-	-	M-FICD	For Europe, Datsun Truck
2	104648-0173	104748-0173 (RF113800C)	MAZDA	RF	○	-	-	-	-	
3	104648-2180	104748-2370 (16700 16A 63)	NISSAN	CD17	-	-	-	○	-	W-CSD, for cold area, M/T.
4	104648-2180	104748-2380 (15700 16A 68)	NISSAN	CD17	-	-	-	○	-	W-CSD, for cold area, A/T.
5	104648-2180	104748-2390 (16700 16A 73)	NISSAN	CD17	○	-	-	○	-	W-CSD, for cold area, M/T.
6	104648-2180	104748-2400 (16700 16A 78)	NISSAN	CD17	○	-	-	○	-	W-CSD, for cold area, A/T.
7	104649-1360	104749-1500 (894124 8420)	ISUZU	C223	-	-	-	-	-	UBS52, '84
8	104649-1360	104749-1510 (894124 8430)	ISUZU	C223	○	-	-	-	-	UBS52, '84
9	104649-1360	104749-1520 (894124 8440)	ISUZU	C223	-	○	-	-	-	UBS52, '84, M/T. for EC Rodeo bighorn
10	104649-1360	104749-1530 (894124 8450)	ISUZU	C223	○	○	-	-	-	UBS52, '84, M/T. for EC, Rodeo bighorn
11	104649-3010	104749-3010 (MD077258)	MITSUBISHI	4D6	-	-	○	-	-	For EC, TC
12	104649-3010	104749-3020 (MD077259)	MITSUBISHI	4D6	○	-	○	-	-	For EC, TC

Note:

(1) The injection pump general ass'y may include some of these additional devices.

The abbreviations are as follows.

PICKUP: Tachometer Pick up

DASHPOT: To prevent vehicle vibration when decelerating ACTUATOR: For F.I.C.D.

M-FICD: Manual Fast Idle Control Device CSD: Cold Start Device

M/T: Manual transmission W-CSD: Wax Type Cold Start Device

TC: Turbo charger A/T: Automatic transmission



Service Information

GENERAL

VE TYPE INJECTION PUMP SERVO VALVE TIMER

A servo valve timer is now used with several of the VE type injection pumps.

The following is an explanation of the servo valve timer's construction and operation.

1. Purpose

It is well-known that the relationship between fuel injection timing and engine performance (power, exhaust gas, engine vibration) is very important.

If actual fuel injection timing differs only slightly from the standard specified timing then diesel engine performance will be adversely effected. With a conventional timer mechanism this results in fluctuations in the injection pump's driving reaction force.

2. A Comparison of Conventional and Servo Valve Timer Construction

2-1 Conventional Type Timer

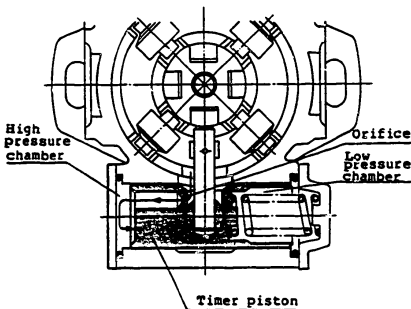


Fig. 1

In the conventional type timer the timer piston's orifice enables pump chamber fuel oil pressure (high fuel oil pressure F_p) to act directly on the timer's high pressure chamber. The timer's low pressure chamber is connected to the fuel inlet, and low pressure acts on the timer's low pressure chamber. The timer's low pressure chamber contains a timer spring, and the timer spring's force (F_s) pushes the timer piston in the retard

ZEXEL

direction. The timer characteristics are decided by the balance of these two opposing forces (F_p , F_s).

As shown in Fig. 1, with this type of timer, the driving reaction force directly effects timer piston movement (fuel injection timing). Fluctuations in the driving reaction force are transferred directly to the timer piston connected to the roller holder and pin, resulting in timer piston movement.

The effect of the driving reaction force can be shown by the formula

$$\Delta X_p = \frac{\Delta P_t \times S_p - F_{dr}}{K}, \text{ where}$$

- ΔX_p : Timer piston displacement (mm)
- ΔP_t : Pump chamber pressure fluctuation (kg/cm^2)
- S_p : Timer piston's effective pressure area (cm^2)
- F_{dr} : Driving reaction force (kg)
- K : Timer spring constant (kg/mm)

Accordingly, as S_p and K are constant, when P_t is stabilized fluctuations in F_{dr} directly affect ΔX_p (fuel injection timing).

2-2 Servo Valve Timer

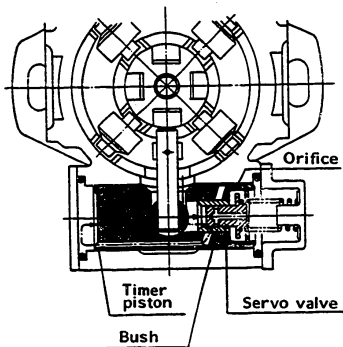


Fig. 2

With the servo valve timer, pump chamber pressure (F_p) does not act directly on the timer's high pressure chamber, but flows through the servo valve before acting on the timer's high pressure chamber.

The timer spring force (F_s) does not push the timer piston, but pushes the servo valve against pump chamber pressure. The servo valve position depends on the balance of these two opposing forces (F_p , F_s), and timer characteristics in turn depend on the servo valve position.

For example, if the timer piston is moved in the retard direction by fluctuations of the driving reaction force, the servo valve position will not change. The servo valve then functions to compensate for the fluctuations in the driving reaction force by allowing the supply of pump chamber pressure to the timer piston. The timer piston is therefore returned to its original position. In other words, the timer piston position is dependant on servo valve position. Actual servo valve movement (ΔX_v) is calculated using the following formula:

$$\Delta X_v = \frac{\Delta P_t \times S_v}{K}$$

Sv: Servo valve's effective pressure area

From this formula the servo valve timer's absorbing of the effect of the driving reaction force on injection timing can be shown. As the effective pressure area directly acted upon by the pump chamber pressure decreases, and correspondingly the spring constant decreases, an improvement in response and hysteresis can be obtained.

3. Operation

3-1 When advance angle is "0"

(Low pump chamber pressure)

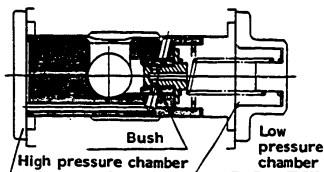


Fig. 3

The pump chamber pressure, compared to the timer spring force, is still low, and the servo valve and the timer piston are pushed fully in the retard direction by the timer spring. The passage between the pump chamber (high pressure side) and the timer's high pressure chamber is closed, and the timer's high pressure chamber is connected to the timer's low pressure chamber (fuel inlet side) by the servo valve.

3-2 When pump chamber pressure has increased.

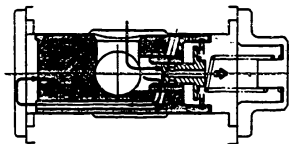


Fig. 4

The pump chamber pressure has increased, pump chamber pressure exceeds the spring force, and the servo valve has been moved to the right.

The passage between the pump chamber and the timer's high pressure chamber is open. The pump chamber pressure acts on the timer's high pressure chamber. Due to this the timer piston is moved in the advance (to the right) direction.

3-3 Stable condition (balanced)

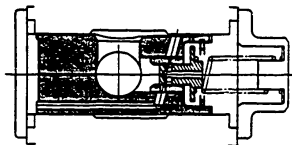


Fig. 5

Pump chamber pressure and timer spring force are balanced, and the servo valve is stationary in a suitable position. The timer piston moves until the bush hole is closed by the servo valve. When the bush hole is completely closed, there will be no change in the timer's high pressure chamber pressure and the timer piston will be stationary.

3-4 When pump chamber pressure has decreased

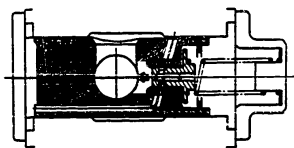


Fig. 6

From the balanced condition, pump chamber pressure has decreased and the servo valve is moved to the left by the timer spring force. The timer's high pressure chamber and the timer's low pressure chamber are connected through the passage in the servo valve. Therefore

the timer high pressure chamber's high pressure escapes to the timer's low pressure chamber and the timer piston moves in the retard (to the left) direction, and, as in 3-3 above, a balanced condition results.

3-5 Maximum advance position

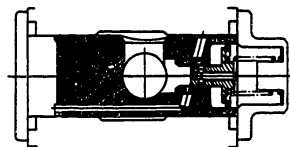



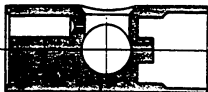



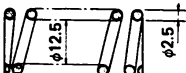


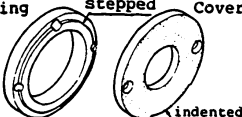
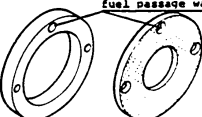
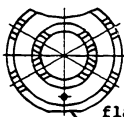
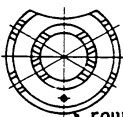
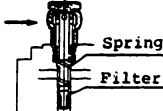
Fig. 7

As the pump chamber pressure has completely overcome the timer spring force, the timer piston moves until its end face contacts the timer cover's low pressure chamber side. That is, if pump chamber pressure further increases, the timer piston cannot move further in the advance

direction. This position is the maximum advance position. According to the above, if the timer piston is moved through the driving reaction force, operations identical to 3-2 and 3-4 above will be repeated until the balanced condition 3-3 is attained.

4. Parts shape

The following shows the differences between servo valve timer and conventional type parts.

Part Name	Servo Valve Timer	Conventional Timer
Timer piston	 <p style="text-align: center;">Orifice</p>	
Servo valve and snap-ring		
Timer spring		
Timer cover (low pressure side)		
Ring and cover (for feed pump)	 <p style="text-align: center;">stepped Cover indented</p>	 <p style="text-align: center;">fuel passage way</p>
Roller holder	 <p style="text-align: center;">flat face</p>	 <p style="text-align: center;">round face</p>
Filter and spring (fuel inlet)	 <p style="text-align: center;">Spring Filter</p>	<p>No spring or filter</p>

4-1 Pump housing

There is no change in the part number - only a change in the shape.
Parts for new and conventional timers can be interchanged.

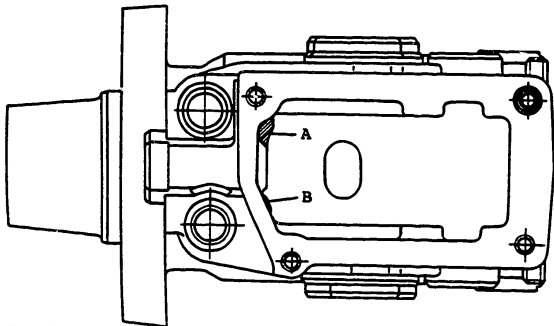


Fig. 9

Sections A and B have not been clad up to the present.

In the new housings, sections A and B (shaded area) are clad during die casting resulting in alterations to the fuel oil transfer passage which are described below.

In the future, all conventional housings will also be clad at sections A and B.

5. Alterations to the fuel oil transfer passage.

During servo valve timer use, to make the entry of metal filings etc. into the pump chamber more difficult, the following modifications to the fuel oil transfer passage have been made.

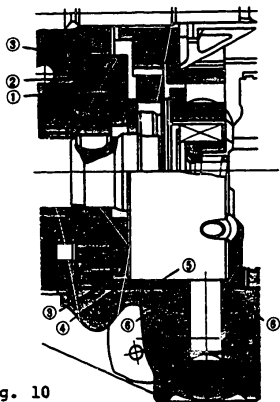


Fig. 10

Servo valve timer - fuel oil passage explanation:

① Feed pump discharge side reservoir → ② Feed pump ring hole → ③ Passage between feed pump ring and feed pump cover → ④ Feed pump cover's cut-away section → ⑤ Roller holder's lower flat face → ⑥ Timer chamber (and pump chamber)

In this case, as fuel oil from the feed pump is not agitated, and is fed directly to the timer chamber, the entry of dust and metal filings etc. is minimized.

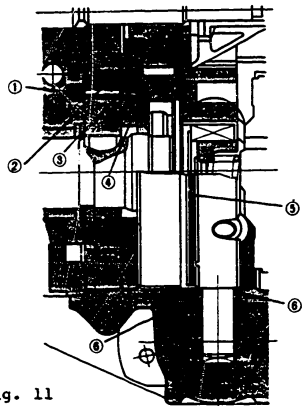


Fig. 11

Conventional timer - fuel oil passage explanation:

① Feed pump discharge side reservoir → ② Feed pump ring hole → ③ Feed pump cover hole → ④ Pump chamber → ⑤ Roller holder's outside groove → ⑥ Timer chamber.

In this case, fuel oil containing metal filings etc. is agitated in the pump chamber, and is then fed to the timer chamber through the roller holders outside groove.

As mentioned in item 4 above, a fuel filter and spring have been added to the fuel inlet. This prevents the entry of dust etc. from the outside to the inside of the pump and when a load timer is used, also prevents agitated fuel oil in containing dust filings etc. in the pump chamber from again being fed to the timer chamber through the feed pump.



Service Information

GENERAL

VE PUMP BOOST COMPENSATOR COVER

A new boost compensator cover for the VE pump has been adopted in addition to the conventional type.

Therefore, there is a difference in the adjustment procedure for the boost compensator stroke. This is explained below.

Construction

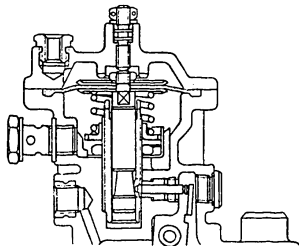


Fig. 1 Conventional type

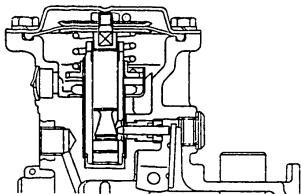


Fig. 2 New type

In the conventional type a stopper bolt, O-ring, washer and locknut are installed in the cover (shown in Fig. 1).

However, these parts are replaced with an indentation in the new cover.

Boost Compensator Stroke Adjustment

In the conventional type, the stopper bolt must be adjusted so that the dimension between the tip of the stopper bolt and the inside face of the cover is approx. 0.5 mm. However, as the dimension from the tip of the indentation to the inside face of the cover is already 0.5 mm in the new cover, it is not necessary to adjust this dimension.

Other boost compensator adjustments do not differ from the conventional procedures.

ZEXEL

Service Dept.



Service Information

CHANGES IN SEALING PROCEDURE FOR VE TYPE INJECTION PUMP

The sealing method for the VE type injection pump's full-load stopper bolt and maximum-speed stopper bolt has been changed from a wire seal to a cap seal. This change is explained below.

Injection Pump Seals

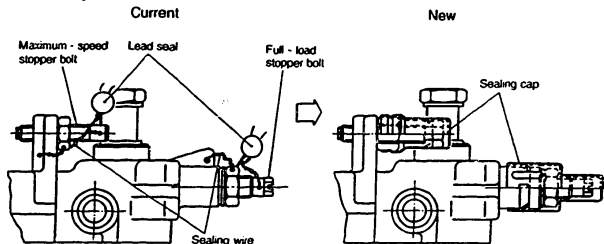


Fig. 1


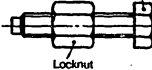
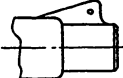
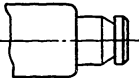
Sealing Caps

Key No.	Part No.	Shape	Depth (mm)	Application
836S	146598-0600 (9 461 612 191)		18	For maximum-speed stopper bolt
	146598-0700 (9 461 612 192)		21	
	146598-0800 (9 461 612 193)		24	
	146598-0900 (9 461 612 194)		27	
835S	146598-1000 (9 461 612 195)		36.5	For full-load stopper bolt
	146598-2700 (9 461 612 281)		24	For NISSAN LD20

Bosch part number are shown in parentheses.

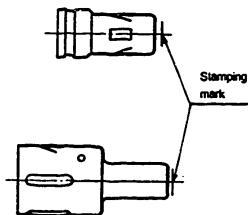
Affected Parts

With the adoption of sealing caps, the shape of the maximum-speed stopper bolt, the locknut, and the governor cover has been changed.

	Current	New
Maximum-speed stopper bolt and locknut		
Governor cover (where full-load stopper bolt and locknut)		

Note

1. The sealing caps must never be reused after repairs or adjustment. Always use new ones.
2. After installing the sealing caps, seal them using a lead seal and sealing wire.
3. Injection pumps which have been adjusted by the engine manufacturers or Z E X E L have the following marks stamped on the end of the sealing caps.







Mark	Remarks
$\phi 3\text{mm}$ 	Installed by ZEXEL
$\phi 3\text{mm}$ 	Installed by engine manufacturer
$\phi 3\text{mm}$ 	Installed by MISA
	Installed by ISUZU (for OPEL)

Fig. 2 Stamping Mark Position

PUMP

GENERAL

October, 1987

S.I. 194 3/7

Date of Application

From April, 1987

Sealing Procedure

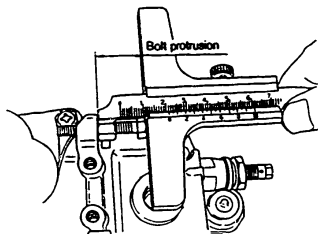


Fig. 3 Measuring the bolt protrusion

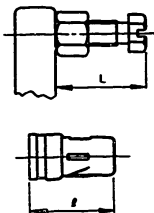


Fig. 4 Bolt protrusion and cap depth



Fig. 5 Inserting the wire

After completing injection pump adjustment, seal the injection pump according to the procedure described below.

Maximum-speed stopper bolt

1. Measure the amount that the maximum-speed stopper bolt protrudes from the governor cover. (Fig. 3)
2. Select a suitable cap using the table below.

Bolt Protrusion L (mm)	Pat No.	Cap Depth l (mm)
16 ~ 19	146598-0600	18
19 ~ 22	146598-0700	21
22 ~ 25	146598-0800	24
25 ~ 28	146598-0900	27

3. Thread the sealing wire through two adjacent holes in the sealing cap. (Fig. 5)

Note : If the wire is difficult to thread, bend the tabs in a little.

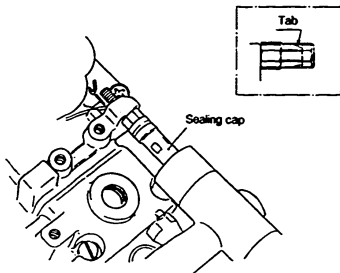


Fig. 6 Installing the cap

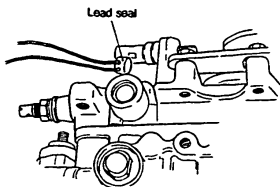


Fig. 7 Installing the lead seal

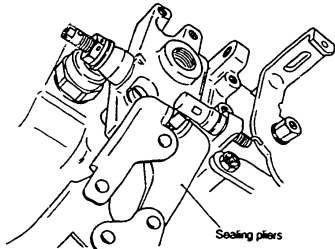


Fig. 8 Sealing the cap

4. Position the sealing cap on the locknut with the wire hanging down and then use a plastic mallet or a similar light tool to install the cap.

Note :

1. Do not reuse sealing caps. Always use new ones.
2. Check that the sealing cap tabs are hooked under the bolt head.

5. Fit the lead seal on the wire. (Fig. 7)

This is done to identify who was responsible for injection pump adjustment.

Note : Do not tie the wire.

6. Crush the lead seal using sealing pliers. (Fig. 8)

Note : Make the gap between the lead seal and the sealing cap as small as possible (to prevent the wire from breaking due to vibration) before crushing the lead seal.

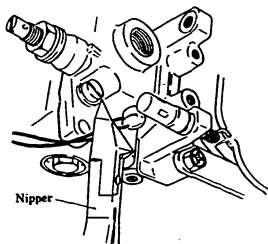


Fig. 9 Cutting the wire

7. Cut off the excess wire using pincers. (Fig. 9)

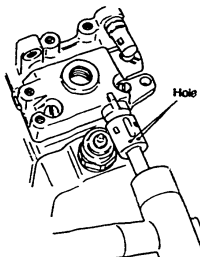


Fig. 10 Installing the cap

Full-load Stopper Bolt

1. Install the sealing cap on the governor cover boss with the two holes facing upward. (Fig. 10)

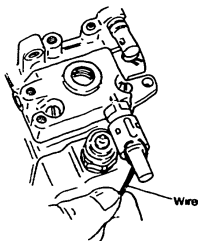


Fig. 11 Attaching the wire

2. Thread the sealing wire through the two holes and position it so that it is slanting downward. (Fig. 11)

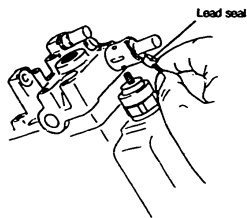


Fig. 12 Installing the lead seal

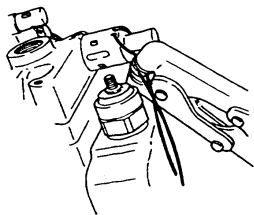


Fig. 13 Sealing the cap



Fig. 14 Cutting the wire

3. Fit the lead seal firmly onto the wire.
(Fig. 12)

4. Crush the lead seal using sealing
pliers. (Fig. 13)

5. Cut off the excess wire using
pincers. (Fig. 14)



Service Information

CHANGES IN SEALING PROCEDURE FOR PE TYPE INJECTION PUMP

The sealing method for the PE type injection pump's full-load stopper bolt and maximum-speed stopper bolt has been changed from a wire seal to a cap seal. This change is explained below.

Sealing Caps

Part No.	Shape	Governor Type	Application
154062-1700 (9 421 610 922)		RAD	Max.-speed stopper bolt (installed on cap nut)
		RFD	Max.-speed & full-load stopper bolt
		RLD	Max.-speed stopper bolt
		RSV	Max.-speed stopper bolt
154062-1800 (9 421 610 923)		RFD	Max.-speed stopper bolt (PE-A base type pump only)
		RSV	Max.-speed stopper bolt (PE-A base type pump only)
154062-1900 (9 421 610 925)		RLD	Full-load stopper bolt
154062-2000 (9 421 610 924)		RSV	Full-load stopper bolt (installed on cap nut)

Note : Bosch part numbers are shown in parentheses.

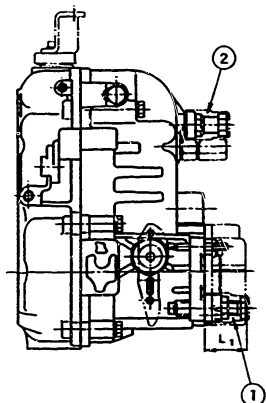
Sealing Cap Positions

Fig. 1 RAD Governor

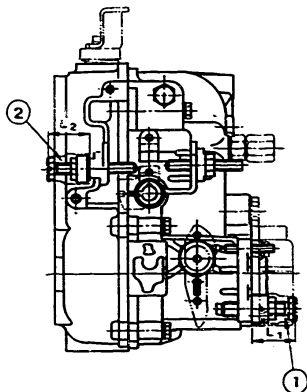


Fig. 2 RFD Governor

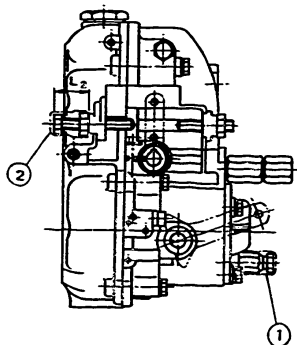
RAD Governor

- ① On full-load stopper
 - Sealing cap part No. : 154062-1700
 - Stopper bolt protrusion : $L_1 = 27 \sim 36$ mm
- ② On maximum-speed stopper
 - Sealing cap part No. : 154062-1700

RFD Governor

- ① On full-load stopper
 - Sealing cap part No. : 154062-1700
 - Stopper bolt protrusion :
 - RFD-B, -C $L_1 = 27 \sim 36$ mm
 - RFD-D $L_1 = 29 \sim 36$ mm
- ② On maximum-speed stopper
 - Sealing cap part No. : 154062-1700 and 154062-1800 *
 - * : (PE · A base type pump only)
 - Stopper bolt protrusion :
 - $L_2 = 25 \sim 34$ mm
 - $L_2 = 20 \sim 26$ mm *
 - * : (PE · A base type pump only)

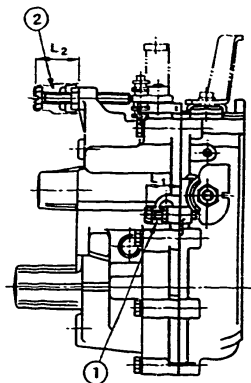
RSV Governor



- ① On full-load stopper
 - Sealing cap part No. : 154062-2000
- ② On maximum-speed stopper
 - Sealing cap part No. : 154062-1700 and 154062-1800 *
 - * : (PE · A base type pump only)
 - Stopper bolt protrusion :
 - $L_2 = 25 \sim 34 \text{ mm}$
 - $L_2 = 20 \sim 26 \text{ mm}^*$
 - * : (PE · A base type pump only)

Fig. 3 RSV Governor

RLD Governor

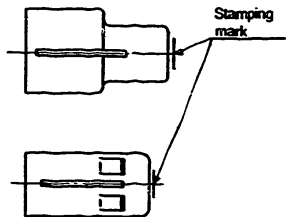


- ① On full-load stopper
 - Sealing cap part No. : 154062-1900
 - Stopper bolt protrusion : $L_1 = 21 \sim 24 \text{ mm}$
- ② On maximum-speed stopper
 - Sealing cap part No. : 154062-1700
 - Stopper bolt protrusion : $L_2 = 29 \sim 36 \text{ mm}$

Fig. 4 RLD Governor

Note

1. The sealing caps must never be reused after repairs or adjustment. Always use new ones.
2. After installing the sealing caps, seal them using a lead seal and sealing wire.
3. Injection pumps which have been adjusted by the engine manufacturers or ZEXEL have the following marks stamped on the end of the sealing caps.



Mark	Remarks
$\phi 3\text{mm}$ 	Installed by Zexel
$\phi 3\text{mm}$ 	Installed by engine manufacturer
	Installed by Mitsubishi Motors
	Installed by Hino Motors

Fig. 5 Stamping Mark Position

Date of Application

From February, 1987

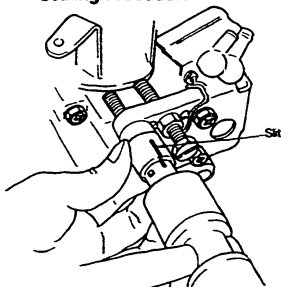
Sealing Procedure

Fig. 6 Installing the sealing cap

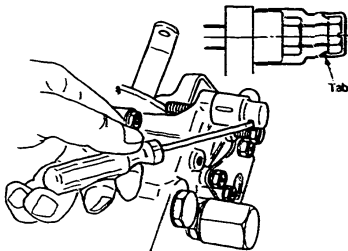


Fig. 7 Bending the tabs

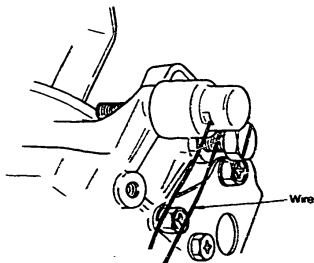


Fig. 8 Attaching the wire

After completing injection pump adjustment, seal the injection pump according to the procedure described below.

Following is an explanation of the sealing procedure for the RLD governor's maximum-speed stopper bolt.

1. Position the sealing cap so that the slit faces upward and install it on the locknut using a plastic mallet or a similar light tool. (Fig. 6)

Note :

1. Do not reuse sealing caps. Always use new ones.
2. Check that the sealing cap tabs are hooked under the bolt head.
2. Bend the two bottom tabs in a little. (Fig. 7)
3. Thread the wire through the two bottom holes, and position it so that it is slanting downward. (Fig. 8)

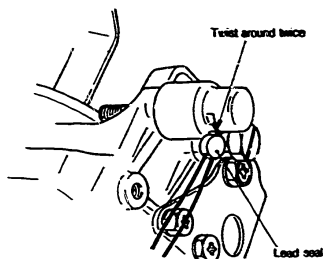


Fig. 9 Installing the lead seal

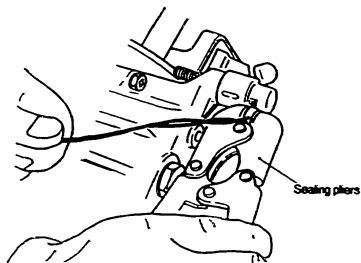


Fig. 10 Sealing the cap

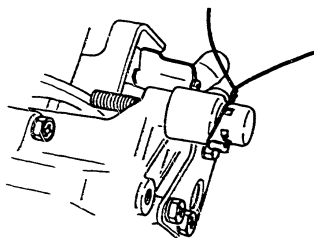


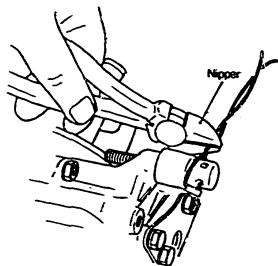
Fig. 11 Fixing the wire

4. Twist the two ends of the wire around twice and then fit the lead seal on the wire. (Fig. 9)

5. Ensure that the lead seal is not loose and then crush the lead seal using sealing pliers. (Fig. 10) This is done to identify who was responsible for injection pump adjustment.

6. Wind the wire around to the top of the sealing cap and then twist the two ends around twice.

Note : Ensure that the wire is wound tightly around the sealing cap.



7. Cut off the excess wire using pincers. (Fig. 12)

Fig. 12 Cutting the wire



Service Information

GENERAL

EXPLANATION OF DIESEL FUEL INJECTION EQUIPMENT PART NUMBERS

ZEXEL products' part numbers are indicated by ten figures, which are divided into six figures preceding a hyphen and four following.

The Assembly Numbers for fuel injection equipment are explained below.

1 0 • • • • — • • • •
(1, 2) (3, 4) (5) (6) (7) (8, 9) (10)

(1, 2) 10 : General assembly number for fuel injection equipment

(3, 4) Diesel fuel injection pumps and related products

10 : Part number of the PE(S)-A(D) type fuel injection pump
Note : PE refers to In-line multi-plunger injection pump.

11~19 : General assembly numbers of the PE(S)-A(D) type fuel injection pump

20 : Part number of the PE-B series fuel injection pump

21~29 : General assembly numbers of the PE-B series fuel injection pump

30 : Part number of the PE-Z series fuel injection pump

31~39 : General assembly numbers of the PE-Z series fuel injection pump

40 : Assembly number of the PF type injection pump
Note : PF refers to Individual-type injection pump.

41 : Assembly number of the PFR type injection pump (with tappet rollers) and the oversized PF type injection pump

42 : Assembly number of the special PF type injection pump

ZEXEL

- 43 : General assembly number (or part number) of the PES-K type injection pump
- 45 : General assembly number of the VM distributor type injection pump
- 46 : Part number of the VE distributor type injection pump
- 47 : General assembly number of the VE distributor type injection pump
- 48 : Part number of the COVEC type injection pump
Note : COVEC means "Computed VE pump Control System".
- 49 : General assembly number of the COVEC type injection pump
- 50 : Nozzle part number or nozzle holder assembly number
- 51 : Nozzle and nozzle holder assembly number
- 52 : Assembly number of the fuel supply pump (or fuel filter)
- 53 : Assembly number of the R, RV, RQ and RQUV series mechanical governors
- 54 : Assembly number of the RSV, RAD and RFD series mechanical governors
- 55 : Assembly number of the MN and MZ type pneumatic governors, RBD type combined pneumatic-mechanical governor and the throttle valve
- 56 : Assembly number of the automatic timing devices and couplings
- 57 : Assembly number of the testing devices and special tools
- 58 : Assembly number of the hydraulic governors
- 59 : Assembly number of the RLD and RGD type mechanical governors and RED type electronic governor
- 60 : Part number of the PE(S)·P(D) type injection pump
- 61~69 : General assembly number of the PE(S)·P(D) type injection pump

- (5)~(7) See page 4 to 28**
- (8, 9) Specific number (from 01 in design order)**
- (10) Modification code**

• Part number of the PE type Injection pump

1 0 1 0 ● ● — ● ● ● ●
 (1, 2) (3, 4) (5) (6) (7) (8, 9) (10)

(5) : Number of cylinders

1~6 : Same as digit

7 : Spare

8 : 8 cylinders

9 : Special

(6) : Plunger diameter (ϕ mm)

(6) \ (3,4)	10 (PE-A)	20 (PE-B)	30 (PE-Z)	60 (PE-P(D))
1	5.0	6.0	10.0	Spare
2	5.5	6.5	11.0	7.0
3	6.0	7.0	12.0	8.0
4	6.5	7.5	13.0	9.0
5	7.0	8.0	13.5	10.0
6	7.5	9.0	14.0	11.0
7	8.0	10.0	15.0	12.0
8	8.5	11.0	16.0	13.0
9	9.0	12.0	—	(each dia. plus 0.5)
0	except 5~9	except 6~12	—	Spare

(7) : Camshaft Installation mark position (viewed from injection pump cover plate or supply pump)

0, 2, 4, 6, 8 : Right side

1, 3, 5, 7, 9 : Left side

● **General assembly number of the PE type injection pump**

$\underline{1} \quad \underline{0} \quad \underline{1} \quad \underline{6} \quad \bullet \quad \bullet \quad - \quad \bullet \quad \bullet \quad \bullet \quad \bullet$
 (1, 2) (3, 4) (5) (6) (7) (8, 9) (10)

(4) : Number of cylinders

(5) : Plunger diameter (ϕ mm)

(4) and (5) are the same as that given in assembly number explanation for PE type injection pumps.

(6) : Attachments

(6)	Supply pump	Governor	Timing device
0	For special combination		
1	Equipped	Equipped	Equipped
2			Not equipped
3			Equipped
4		Not equipped	Not equipped
5		Equipped	
6	For spare		
7			
8			
9			

Note : In the case of the PE-P(D) type injection pump.

0 : Not equipped with supply pump, governor or timing device

9 : For special combination

(7) : Engine manufacturer

(7) \ (3)	1 (PE-A)	2 (PE-B)	3 (PE-Z)	6 (PE-P(D))
Isuzu	0, 4, 7, 8	—	—	1, 6
Mitsubishi	1, 6	—	—	2, 7
Hino	2, 5	—	—	3, 8
Komatsu	3	2	—	4, 9
Nissan D.	9	0, 4	—	0, 5
Hitachi	—	3	—	—
Daihatsu	—	1	—	9
Shinko	—	1	—	9
Niigata	—	1	—	9
etc.	9	9	—	4, 9

Note : In the case of the PE-Z series injection pump, (7) to (9) is the specific number.

● PF type injection pump assembly number

1 0 4 0 ● ● — ● ● ● ●
 (1, 2) (3, 4) (5) (6) (7) (8, 9) (10)

(5) : Injection pump type

0 : Spare 5 : PF1W type
 1 : PF1A type 6 : PF1D type
 2 : PF1B type 7~9 : Spare
 3 : PF1Z type
 4 : PF1C type

(6): Plunger diameter (ϕ mm)

(6) \ (5)	1 (PF1A)	2 (PF1B)	3 (PF1Z)	4 (PF1C)	5 (PF1W)	6 (PF1D)
0	Except 5~9	—	—	—	—	—
1	5.0	6.0	10.0	10.0	15.0	18.0
2	5.5	6.5	11.0	11.0	16.0	19.0
3	6.0	7.0	12.0	12.0	17.0	20.0
4	6.5	7.5	13.0	13.0	18.0	21.0
5	7.0	8.0	13.5	14.0	19.0	22.0
6	7.5	9.0	14.0	15.0	20.0	—
7	8.0	10.0	15.0	16.0	21.0	—
8	8.5	—	16.0	—	22.0	—
9	9.0	—	—	—	23.0	—

(7): Configuration of mounting flange and control rack

0, 1, 2, 6, 7 : Parallel
3, 4, 5 : Perpendicular
8, 9 : Special

• Oversized PF type injection pump assembly number

$\frac{1}{(1, 2)}$ $\frac{0}{(3, 4)}$ $\frac{4}{(5)}$ $\frac{1}{(6)}$ $\frac{\bullet}{(7)}$ $\frac{\bullet}{(8)}$ $\frac{\bullet}{(9)}$ $\frac{\bullet}{(10)}$

(5): Injection pump type

2 : PF1BD type 6 : PF1DD type
3 : PF1ZD type 7 : PF1ED type
4 : PF1CD type 8 : PF1FD, PF1FX, PF1HD and PF1HX
 types
5 : PF1WM and 9 : PF1DD---C, Piel Stick, and MAN
 PF1K types types

(6): Plunger diameter (ϕ mm)

(5) \ (6)	0	1	2	3	4	5	6	7	8	9	
2 PF1BD		11	12								
3 PF1ZD		15	16								
4 PF1CD	16	17	18	19	20	21	22			12	
5 PF1WM	20				24.5	14	17	18	23	25	
PF1K		18	20	21							
6 PF1DD		21	22	23	24	25	26	27	28	29	
7 PF1ED	35	26	27	28	29	30	32	34	36	31	
8	PF1HD		40	42	46	48	50	56	44		
	PF1FD										
	PF1FX									53	
9	PF1DD-C	For MAN	30	31	32				28	29	
	Piel Stick						27	30	34		
	MAN										

(7): Configuration of mounting flange and control rack

0~2, 6, 7: Parallel

3~5 : Perpendicular

8, 9 : Special

● PFR type injection pump assembly number

$\frac{1}{(1)}$ $\frac{0}{(2)}$ $\frac{4}{(3)}$ $\frac{1}{(4)}$ $\frac{\bullet}{(5)}$ $\frac{\bullet}{(6)}$ — $\frac{\bullet}{(7)}$ $\frac{\bullet}{(8)}$ $\frac{\bullet}{(9)}$ $\frac{\bullet}{(10)}$

(5): Injection pump type

0 : PFR-K(V) type

1 : PFR-A(V) type

2 : PFR-P type

3 : PFR-KX type

4 : PFR-CD type

(6) : Plunger diameter (ϕ mm)

(5) \ (6)	0	1	2	3	4	5	6	7	8	9
0 (PFR-K)	Except 4~8	4.0	4.5	5.0	5.5	6.0	6.5	7.0	7.5	8.0
1 (PFR-A)	Except 5~9	5.0	5.5	6.0	6.5	7.0	7.5	8.0	8.5	9.0
2 (PFR-P)										12.0
3 (PFR-KX)				5.0	5.5	6.0	6.5	7.0	7.5	8.0
4 (PFR-CD)								18		20

(7) : Number of cylinders

Same as digit

● PF special type injection pump assembly number

1 0 4 2 ● ● — ● ● ● ●
 (1, 2) (3, 4) (5) (6) (7) (8, 9) (10)

(5) : Injection pump type

- 0 : For pile-driver and PFR-MD type
- 1 : PF1GD and PF1GV types
- 2 : PF1ED...F type
- 3 : PF1Z type for Mitsubishi and PFR-RV type
- 4 : PF1C(D) type for Mitsubishi, PF1CX and PFR-CV types
- 5 : PF1W type for Mitsubishi, PF1WX, PF1WV and PF1WV...B types
- 6 : PF1GD type for Mitsubishi, PF1GX and PF1SV types
- 7 : PF1D(D) type for Mitsubishi, PF1DX, PF1DX...B and PF1TV types
- 8 : PF1ED type and PF1EX types
- 9 : PFR-KD type

(6) : Plunger diameter (ϕ mm)

(5) \ (6)	0	1	2	3	4	5	6	7	8	9	
0	Pile-driver	For									
	PFR-MD	P.D.	3.0	3.5	4.0	4.5	5.0	5.5	6.0		
1	PF1GD	20	21	22	23	24	25	26			
	PF1GV	26									
2	PF1ED ...F	32	37	38	39	40	41	42	43	44	36
3	PF1Z		10	12	14	16					
	PFR-RV ^o	20	21	22	23	24	25	26			
4	PF1C (D)		14	16	17	18	19			15	
	PF1CX, RCV	16	17	18	19	20					
5	PF1W		20	21	22	23					
	PF1WX, WV			16	17	18	19	20	21	22	
6	PF1GD		21	22	23	24	25	26			
	PF1GX	20	21	22	23	24	25	26	27		
	PF1SV					24	25	26	27	28	
7	PF1D (D)		21	22	23	24, 25	26	27	28	29	
	PF1DX	24	25	26	27	28	29	30	31	32	33
	PF1TV	26	27	28	29	30	31	32	33	34	
8	PF1ED		28	30	32	33	34	36	38		
	PF1EX	30, 31	32, 33	34, 35	36, 37	38, 39	40, 41	42			
9	PFR-KD		4.0	4.5	5.0	5.5	6.0	6.5	7.0	7.5	

(7) - ①: Configuration of mounting flange and control rack (except PFR-KD and PFR-MD type pumps)

0~2, 6, 7: Parallel

3 : Perpendicular

4 : Parallel

5 : Perpendicular

8, 9 : Special

} For " X " series

(7) - ②: Number of cylinders (for PFR-KD and PFR-MD type pumps)
Same as digit

(7) - ③: Pile-driver type

0 : Type 12

1 : Type 22

2 : Type 40

● Part number of the PES-K type Injection pump

1 0 4 3 0 0 — ● ● ● ●
 (1, 2) (3, 4) (5) (6) (7) (8, 9) (10)

(5) : Injection pump type

0 : PES-K type

(6) : Injection pump part number

0 : PES-K type

(7) : Number of cylinders

1 : 1 cylinder

0, 2, 5 : 2 cylinders

3, 6 : 3 cylinders

4, 7 : 4 cylinders

● General assembly number of the PES-K type Injection pump

1 0 4 3 0 ● — ● ● ● ●
 (1, 2) (3, 4) (5) (6) (7) (8, 9) (10)

(5) : Injection pump type

0 : PES-K type

(6) : Number of cylinders

1 : 1 cylinder

2 : 2 cylinders

3 : 3 cylinders

4 : 4 cylinders

(7) : Plunger diameter (ϕ mm)

(7)	0	1	2	3	4	5	6
Plunger dia.	5.0	5.5	6.0	6.5	7.0	7.5	6.5

• **General assembly number of the VM type injection pump**

1 0 4 5 ● ● — ● ● ● ●
 (1, 2) (3, 4) (5) (6) (7) (8, 9) (10)

(5) : Number of cylinders and the direction of rotation (viewed from the pump's drive side)

- 0 : 2 cylinders; Clockwise rotation
- 1 : 2 cylinders; Counterclockwise rotation
- 2 : 3 cylinders; Clockwise rotation
- 3 : 3 cylinders; Counterclockwise rotation
- 4 : 4 cylinders; Clockwise rotation
- 5 : 4 cylinders; Counterclockwise rotation
- 6 : 6 cylinders; Clockwise rotation
- 7 : 6 cylinders; Counterclockwise rotation
- 8 : Spare
- 9 : Spare

(6) : Plunger diameter (ϕ mm)

(6)	0	1	2	3	4	5	6	7
Plunger dia.	7.0	7.5	8.0	8.5	9.0	9.5	10.0	10.5

(7) : Engine manufacturer

- 0 : Isuzu
- 1 : Nissan
- 2 : Mazda

- General assembly number (or part number) of the VE type injection pump

1 0 4 7 ● ● — ● ● ● ●
(1, 2) (3, 4) (5) (6) (7) (8, 9) (10)

(3, 4) : 46~49 VE type injection pump

- 46 : VE type injection pump assembly number
- 47 : VE type injection pump general assembly number
- 48 : COVEC (Computed VE pump Control System) type injection pump assembly number
- 49 : COVEC type injection pump general assembly number

(5) : Number of cylinders

- 0 : Spare
- 1 : Spare
- 2 : 2 cylinders
- 3 : 3 cylinders
- 4 : 4 cylinders
- 5 : 5 cylinders
- 6 : 6 cylinders
- 7 : Spare
- 8 : 8 cylinders
- 9 : Spare

(6) : Plunger diameter (ϕ mm)

- 0 : 10
- 1 : 11
- 2 : 12
- 3 : 13
- 4 : 14
- 5 : Spare
- 6 : Spare
- 7 : Spare
- 8 : 8
- 9 : 9

(7) : Engine manufacturer

- 0 : Mazda
- 1 : Isuzu
- 2 : Nissan Motor
- 3 : Mitsubishi
- 4 : Nissan Diesel
- 5 : Spare
- 6 : Spare
- 7 : Spare
- 8 : Spare
- 9 : Others

● **Nozzle part number**

1 0 5 0 ● ● — ● ● ● ●
 (1, 2) (3, 4) (5) (6) (7) (8, 9) (10)

(5) : Nozzle type

- 0 : DN type (pintle-type)
- 1 : DL type (hole-type)
- 2 : Special type

(6) : Nozzle size (or application)

① For DN and DL type nozzles

(6)	0	1	3	4	5	6	7	9
Size	S	T	V	K	DLL-S	Special	P	Nozzle & spacer ass'y

② For special type nozzles

- 0, 2, 3: For burner
- 1 : Spacer
- 4 : For Jet-loom
- 8 : Replacement nozzle

(7) : Nozzle classification

① For pintle-type nozzles

- 0 : Pintle-type
- 1 : Throttle-type

② For hole-type nozzles

- 0~3, 9 : Non-cooled nozzle
- 4~8 : Liquid-cooled nozzle

● Nozzle holder assembly number

$\frac{1}{(1)}$ $\frac{0}{(2)}$ $\frac{5}{(3)}$ $\frac{0}{(4)}$ $\frac{\bullet}{(5)}$ $\frac{\bullet}{(6)}$ — $\frac{\bullet}{(7)}$ $\frac{\bullet}{(8)}$ $\frac{\bullet}{(9)}$ $\frac{\bullet}{(10)}$

(5) : Nozzle holder type

3 : KB, KBL type	7 : KCA type
4 : KBA type	8 : KD, KDL type
5 : KBF type	9 : Special type
6 : KC type	

(6) : Nozzle holder size

0 : S type	5 : V type
1 : SD type	6 : W type
2 : T type	7 : (K) type
3 : TD type	8 : P type
4 : U type	9 : Spare

(7) : Length of installed section (mm)

(7) \ (6)	P, S type	T type	U, V, W type
0	Less than 30	Less than 50	Less than 100
1	31 ~ 35	51 ~ 80	101 ~ 150
2	51 ~ 70	81 ~ 100	151 ~ 200
3	71 ~ 90	101 ~ 125	201 ~ 250
4	91 ~ 110	126 ~ 150	251 ~ 300
5	111 ~ 130	151 ~ 175	301 ~ 350
6	131 ~ 150	176 ~ 200	351 ~ 400
7	151 ~ 170	201 ~ 225	401 ~ 450
8	171 ~ 190	226 ~ 250	451 ~ 500
9	More than 191	More than 251	More than 501

● Nozzle and nozzle holder assembly number

1 0 5 1 ● ● — ● ● ● ●
(1, 2) (3, 4) (5) (6) (7) (8, 9) (10)

(5) : Nozzle holder type

- | | |
|-----------------------------|------------------------------------|
| 0 : KB(L) type | 5 : KD(L), KDA(L) and KDE(L) types |
| 1 : KBA(L) and KBE(L) types | 6 : Injector |
| 2 : KBF type | 7 : Spare |
| 3 : KC type | 8 : Spare |
| 4 : KCA type | 9 : Special type |

(6) : Nozzle size

- | | |
|-------------|--------------|
| 0 : S type | 5 : V type |
| 1 : SD type | 6 : W type |
| 2 : T type | 7 : (K) type |
| 3 : TD type | 8 : P type |
| 4 : U type | 9 : Spare |

(7) : Nozzle type

- 0 : Pintle-type DN
- 1 : Throttle-type DN (includes Pintaux nozzle)
- 2 : Throttle-type DN (includes Pintaux nozzle)
- 3 : DL type
- 4 : DLL type
- 5 : DLF type
- 6 : Spare
- 7 : DLL type (for two-spring nozzle holders)
- 8 : DN and DL(L) types (for nozzle holders with nozzle-lift sensor)
- 9 : Special type

● **Assembly number of the fuel supply pump (or fuel filter)**

$\frac{1}{(1, 2)}$ $\frac{0}{(3, 4)}$ $\frac{5}{(5)}$ $\frac{2}{(6)}$ ● ● — ● ● ● ●
 (1, 2) (3, 4) (5) (6) (7) (8, 9) (10)

(5) : Supply pump (or filter) type

- 0 : K type supply pump
- 1 : KE type supply pump
- 2 : KS type supply pump
- 3 : KD type supply pump
- 4 : Special type supply pump
- 5 : Single-stage filter
- 6 : Two-stage filter
- 7 : Special type filter
- 8 : Special

(6) - ① : Supply pump size and housing material

Size	Housing's material
0 : A type	Cast iron
1 : A type	Aluminum
2 : B type	Cast iron
3 : B type	Aluminum
4 : Z type	Cast iron
5 : Z type	Aluminum
6 : F type	Cast iron
7 : P type	Aluminum (or cast iron)
8 : Diaphragm type supply pump	Aluminum
9 : Spare	

(6) - ② : Fuel filter capacity

0 : 0.5 liter	4 :	}	Spare
1 : 1.0 liter	5 :		
2 : 1.1 liter	6 :		
3 : 2.0 liter	9 :		

6) - ③ : Special product's name

- 0 : Fuel cut valve

(7) - ① : Supply pump attachments

(6)	Priming pump	Filter
0	Not equipped	Not equipped
1	Equipped	
2	Not equipped	Equipped
3	Equipped	
4		
5		
		Not equipped

(7) - ② : Filter element material

- 0 : Filter paper
- 1 : Silk cloth
- 2 : Felt
- 3 : Wire mesh
- 4 : Others
- 5 : Silk cloth and filter paper
- 6 : Silk cloth and felt
- 7~9 : Spare

- R, RV, RQ and RQUV series mechanical governors' assembly number

1 0 5 3 ● ● — ● ● ● ●
(1, 2) (3, 4) (5) (6) (7, 8, 9) (10)

(5): Governor type

- | | |
|------------------|----------------|
| 0 : RQ type | 5 : RQUV type |
| 1 : RQV type | 6 : RQUVD type |
| 2 : R(P) type | 7 : RP-Z type |
| 3 : RV, RPV type | 8 : Spare |
| 4 : RQU type | 9 : Spare |

(6): Applicable injection pump size

- 0 : A type (RQ, RQV)
- 1 : A type (with torque control device)
- 2 : B type (RQ, RQV, R, RP, RV, RPV)
- 3 : B type (with torque control device)
- 4 : Z type (RQU, RQUV, RQUVD, RP)
- 5 : Z type (with torque control device)
- 6 : P type
- 7 : P type (with torque control device and other devices)

(7, 8, 9): Specific number (from 001 in design order)

● RSV, RAD and RFD series mechanical governors' assembly number

1 0 5 4 ● ● — ● ● ● ●
(1, 2) (3, 4) (5) (6) (7, 8, 9) (10)

(5): Governor type and installation position (viewed from the injection pump cover plate)

Type	Position
0 : RSV type	Right side
1 : RSV type	Left side
2 : RSVD type	Right side
3 : RSVD type	Left side
4 : RSUV type	Right side
5 : RSUV type	Left side
6 : RAD type	Right side
7 : RAD type	Left side
8 : RFD type	Right side
9 : RFD type	Left side

(6): Applicable injection pump size

- 0 : A type
- 1 : A type (with boost-compensator)
- 2 : A type (with torque control device or torque spring)
- 3 : B type
- 4 : B type (with torque control device or torque spring)
- 5 : Z type
- 6 : Z type (with torque control device or torque spring)
- 7 : P(D) type
- 8 : P(D) type (with torque control device or torque spring)

(7, 8, 9) : Specific number (from 001 in design order)

- Pneumatic governor, RBD type combined pneumatic-mechanical governor and throttle valve assembly number

1 0 5 5 ● ● — ● ● ●
(1, 2) (3, 4) (5) (6) (7) (8, 9) (10)

(5) : Type

- 0 : M type pneumatic governor
- 1 : MN type pneumatic governor
- 2 : MZ type pneumatic governor
- 3 : Spare
- 4 : RBD type combined pneumatic-mechanical governor
- 5 : Spare
- 6 : Standard type throttle valve
- 7 : Special type throttle valve
- 8 : Intake-air shutter
- 9 : Spare

(6) — ① Applicable injection pump size (for pneumatic governor)

- .0 : A type
- 2 : Spare (for MZ type governor)
- 9 : A type (for special type)

(6) — ② Applicable injection pump size (for RBD type combined governor)

- 0 : A type (with MN type governor)
- 1 : Spare
- 2 : A type (with MZ type governor)
- 3 : Spare

(7) : Diaphragm diameter (for pneumatic governor and combined governor)

- 3, 4, 6: ϕ 60 mm, 8 : ϕ 80 mm

(6, 7) : Throttle valve diameter

- 38 : ϕ 38 mm, 56 : ϕ 56 mm

• Automatic timing devices' and couplings' assembly number

$\frac{1}{(1, 2)}$ $\frac{0}{(3, 4)}$ $\frac{5}{(5)}$ $\frac{6}{(6)}$ — $\frac{\bullet}{(7)}$ $\frac{\bullet}{(8)}$ $\frac{\bullet}{(9)}$ $\frac{\bullet}{(10)}$

(5): Type

- 0 : Manual type timing device
- 1 : External type timing device (SA series ; pin type)
- 2 : Built-in type timing device (SCD series ; pin type)
- 3 : External type timing device (SP series ; roller type)
- 4 : Built-in type timing device (SPZ series ; roller type)
- 5 : Spare
- 6 : Couplings
- 7, 8 : Eccentric cam type timing devices
- 9 : Electronic-hydraulic timing device

(6) - ① Camshaft diameter and direction of rotation (except EC type timing device)

(6)	Camshaft dia. (ϕ mm)	Direction of rotation (viewed from drive side)
1	17	Counterclockwise
2	17	Clockwise
3	20	Counterclockwise
4	20	Clockwise
5	25	Counterclockwise
6	25	Clockwise
9	Special type	

(6) - ② Electronic-hydraulic timing device type and drive-shaft diameter (ϕ mm)

(6)	Timing device type	Drive-shaft dia. (ϕ mm)
0	SAGH	20
1	SPGH	25
2	SAMH	20
3	SPMH	25

(6, 7) : Timing device type, camshaft diameter and direction of rotation (for EC type timing device)

(1~5)	(6, 7)	Timing device type	Drive shaft dia. (ϕ mm)	Direction of rotation
10567	0-1 0-4	SCDM (standard type)	17	Clockwise
10567	0-5 0-9	SCDM (standard type)	17	Counterclockwise
10567	1-0 1-4	SCDM (standard type)	20	Clockwise
10567	1-5 1-9	SCDM (standard type)	20	Counterclockwise
10567	2-0 2-4	SAG (standard type)	20	Clockwise
10567	2-5 2-9	SAG (standard type)	20	Counterclockwise
10567	6-0 6-4	SCDM (gear installed on pump side)	20	Clockwise
10567	6-5 6-9	SCDM (gear installed on pump side)	20	Counterclockwise
10568	0-0 0-4	SPG (standard type)	20	Clockwise
10568	0-5 0-9	SPG (standard type)	20	Counterclockwise
10568	1-0 1-4	SPG (standard type)	25	Clockwise

(1~5)	(6, 7)	Timing device type	Drive shaft dia. (ϕ mm)	Direction of rotation
10568	1-5 ↓ 1-9	SPG (standard type)	25	Counterclockwise
10568	2-0 ↓ 2-4	SDG (standard type)	25	Clockwise
10568	2-5 ↓ 2-9	SDG (standard type)	25	Counterclockwise
10568	7-0 ↓ 7-4	SPM (special type)	25	Clockwise
10568	7-5 ↓ 7-9	SPM (special type)	25	Counterclockwise

- (7)-① : Direction of rotation (for Electronic-hydraulic timing device)
- 0~4 : Clockwise rotation (viewed from the drive side)
- 5~9 : Counterclockwise rotation (viewed from the drive side)
- (7)-② : Coupling type
- 0 : Laminated coupling
- 1 : Oldham's coupling (with Bakelite tip)
- 2 : Oldham's coupling (laminated Bakelite disk)
- 3 : Oldham's coupling (steel disk and nylon bushings)
- 4 : Special type (with timing device and air compressor)
- (7)~(9) : Specific number of the pin (or roller) type timing devices (from 001 in design order)

• Testing device and special tools' assembly number

1 0 5 7 ● ● — ● ● ● ●
(1, 2) (3, 4) (5) (6) (7, 8, 9) (10)

(5, 6) : Classification

- 50 : Smoke meter
- 60 : Pump test stand model 5NP
- 61 : Pump test stand model 7NP
- 62 : Pump test stand model 15NP
- 65 : Attachments for pump test stand model 5NP
- 80 : Test nozzle or test nozzle holder
- 81 : Injection pump's fixing stand or driving stand
- 82 : Measuring devices
- 83 : Timing checker or stroboscope
- 84 : Attachments (couplings, heater, etc.)
- 85 : Nozzle tester
- 88 : Stroboscope
- 89 : Nozzle cleaning tool
- 90 : Special tool kit for disassembly and reassembly of the injection pump
- 92 : Extractor
- 94 : Universal vise ass'y
- 99 : Special tools

(7)~(9) : Specific number (from 001 in design order)

• Hydraulic governors' assembly number

1 0 5 8 • • — • • • •
(1, 2) (3, 4) (5) (6) (7) (8, 9) (10)

(5) : Applicable pump size or governor type

- 0 : For PE-Z, ZV and ZWM type pumps
- 1 : For PE-P type pump
- 2~4 : Spare (for in-line type pumps)
- 5 : RHD6 type governor
- 6 : RHD10 and RHD35 type governors
- 7 : Electro-hydraulic governor
- 8, 9 : Spare (for individual-type pumps)

(6) : Direction of pump rotation (viewed from the pump's drive side) and governor installation position (viewed from the pump's cover plate side)

For in-line type pumps

- 0 : Clockwise rotation ; right side
- 1 : Clockwise rotation ; left side
- 2 : Counterclockwise rotation ; right side
- 3 : Counterclockwise rotation ; left side

For individual-type pumps

- 4 : Clockwise rotation
- 5 : Counterclockwise rotation
- 6 : Clockwise and counterclockwise reversible rotation
- 7~9 : Spare

(7): Attachments

- 3 : Lever control type (LC type)
- 4 : With pneumatic controller (FC type)
- 5 : With governor motor (MC type)
- 6 : With governor motor (MC type)
- 7 : With limit-switch-equipped governor motor (MCL type)
- 8 : With limit-switch-equipped governor motor (MCL type)
- 9 : With hydraulic controller (HC type) and others

● RLD and RGD type mechanical governors' and RED type electronic governor assembly number

1 0 5 9 ● ● — ● ● ● ●
(1, 2) (3, 4) (5) (6) (7) (8, 9) (10)

(5) : Governor type

- 0 : RGD type mechanical governor
- 2 : RLD type mechanical governor (for PE-A type injection pump ; installed on pump's right side)
- 3 : RLD type mechanical governor (for PE-A type injection pump ; installed on pump's left side)
- 4 : RLD type mechanical governor (for PE-P type injection pump)
- 5 : RED type electronic governor

(6) - ① : RGD governor classification

- 0 : Assembly
- 2 : General assembly

(6) - ② : Additional devices (For RLD type governor)

- 0 : Not equipped
- 1 : With torque cam
- 2 : Spare
- 3 : Spare

(6) - ③ : Applicable injection pump size (For RED governor)

- 0 : REDII type governor for PE-A pump
- 1 : REDII type governor for PE-P pump
- 2 : REDIII type governor for PE-P pump
- 3 : REDIII type governor for PE-A pump
(installed on pump's right side)
- 4 : REDIII type governor for PE-A pump
(installed on pump's left side)
- 5 : REDIII type governor for PE-ZW pump

(7) - ① : Engine manufacturer (for RGD governor)

- 0,1 : Mazda 3 : Others

(7)~(9) : Specific number of RLD and RED type governors (from 001 in design order)



Service Information


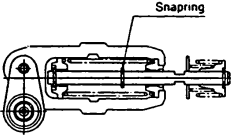
GENERAL

MODIFICATION TO VE TYPE INJECTION PUMP FOR ISUZU 4JB1T ENGINE

The control shaft of the VE type injection pump (minimum-maximum speed specifications) for the 4JB1T engine has been modified. The modification is described below.

1. Modification

A snapping has been added to the control shaft (key no. 68).

	Current	New
Part No.	146513-6820*	Unchanged
Shape		

2. Applicable Pump Part Numbers

104741-6351*, -6352*

3. Interchangeability

Only current control shafts can be replaced with new.

4. Date of Application

Injection pumps manufactured from September, 1988.

* Bosch Nr., see cross reference DKKC - Bosch, microfiche HB 30, HB 31.

ZEXEL



Service Information

GENERAL

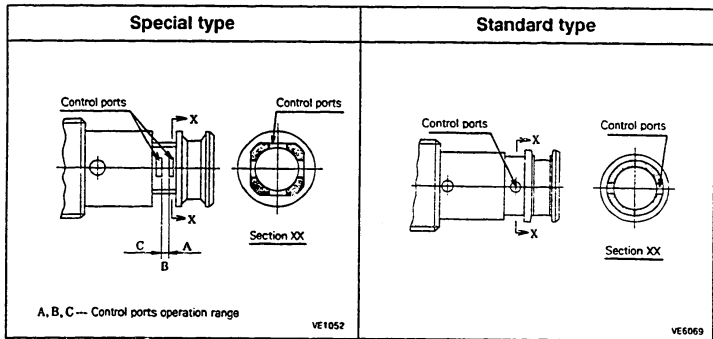
VE Type Injection Pump Regulating Valve

A regulating valve with specially shaped control ports has been adopted on some VE type injection pumps utilizing timing devices with two-stage characteristics.

1. Purpose

- ① To comply with exhaust gas emission regulations and reduce vehicle acceleration noise.
- ② To reduce white smoke in the intermediate speed range.

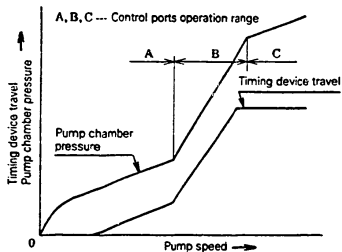
2. Regulating valve shape



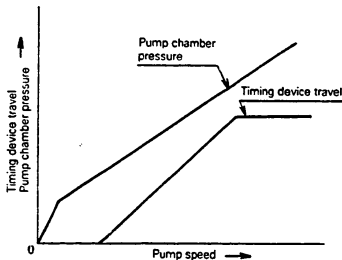
ZEXEL

3. Characteristics

Special type



Standard type



4. Adjustment (supply pump pressure and timing device travel)

As the timing device is the externally adjustable type, refer to the separate Service Information bulletin (S.I. 223) for the adjustment procedure.

5. Applicable pump part numbers

104741-4073,* -4092*

* Bosch Nr., see cross reference DKKC - Bosch, microfiche HB 30, HB 31.